

Reflections (F)

Draw the reflected image.

Reflect over $x = 3$.

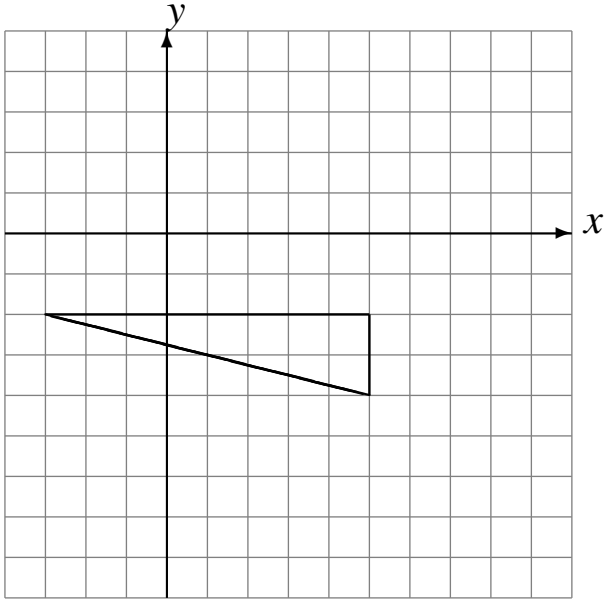

Reflect over $x = -3$.

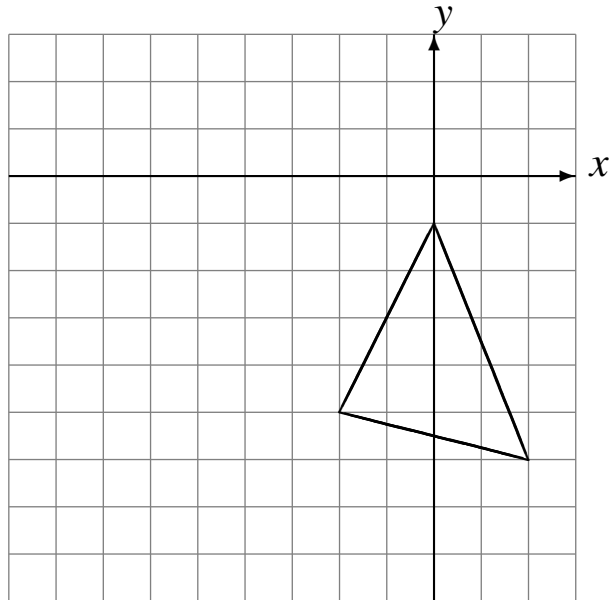

Reflect over $x = 2$.

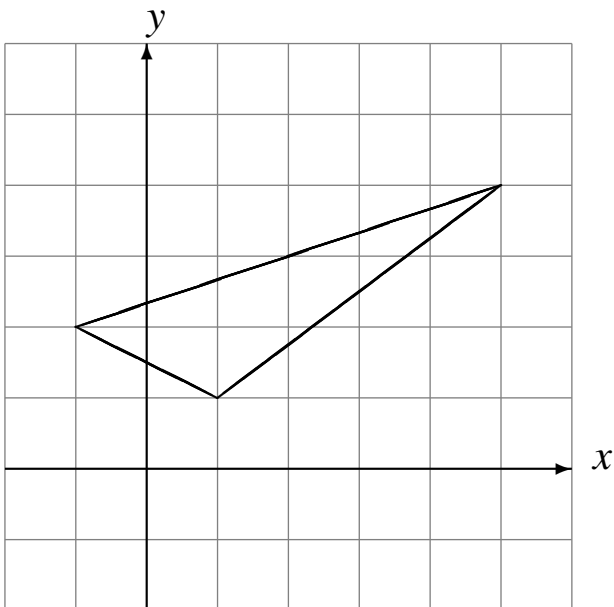

Reflect over $x = 0$.

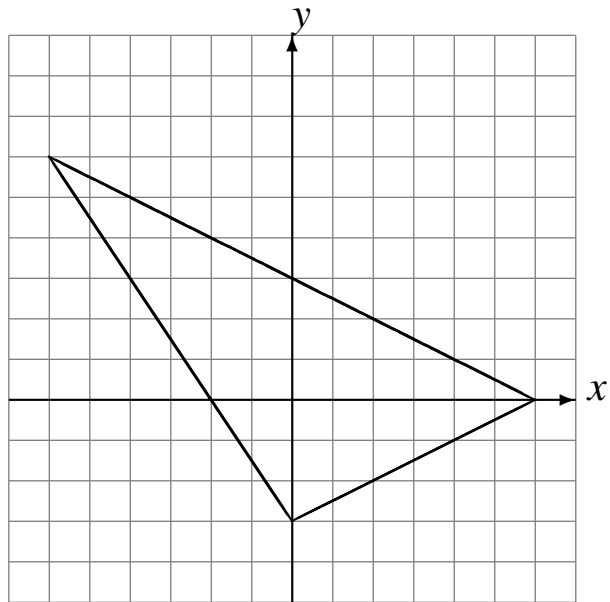

Reflections (F) Answers

Draw the reflected image.

Reflect over $x = 3$.

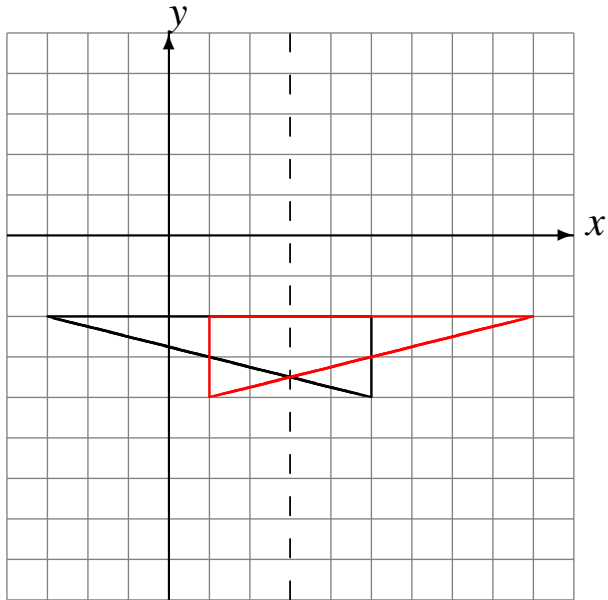

Reflect over $x = -3$.

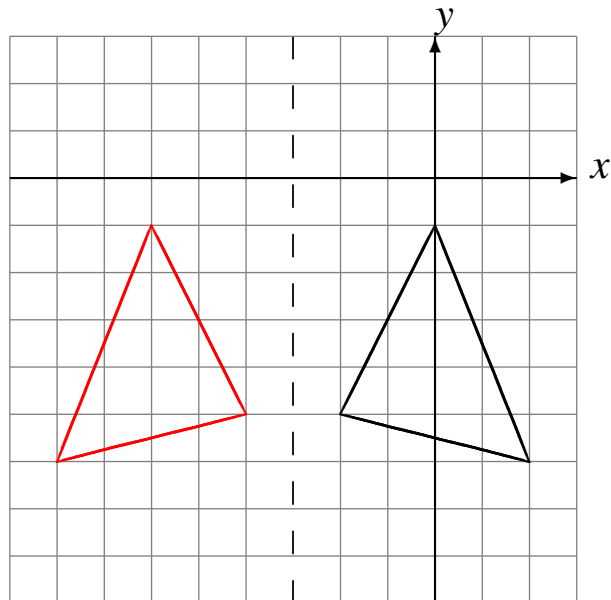

Reflect over $x = 2$.

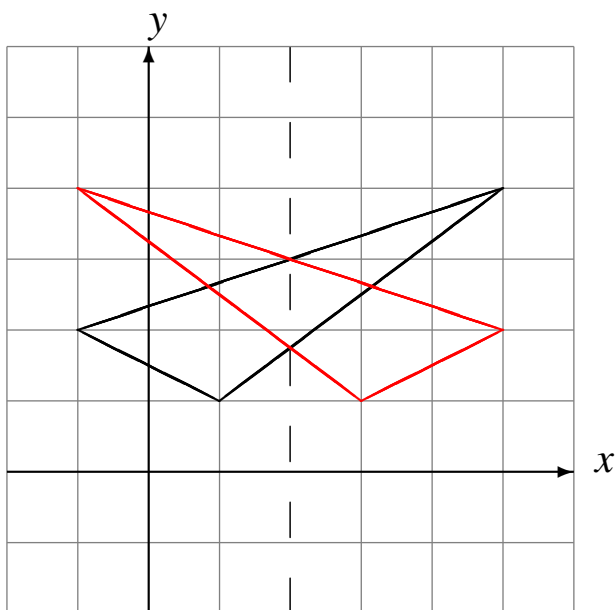

Reflect over $x = 0$.

